

L-R SOLID ROTARY HYDRAULIC CYLINDERS (BUILT-IN CHECK VALVE)

中實油壓迴轉缸 (附止逆裝置)

1. 超薄迴轉閥體

縮短外型長度，可以減少機械組裝的干涉及重量負擔。

2. 安全構造

內藏止回閥設計，於突發之壓降時仍可保持推力。



尺寸圖 » Dimensions

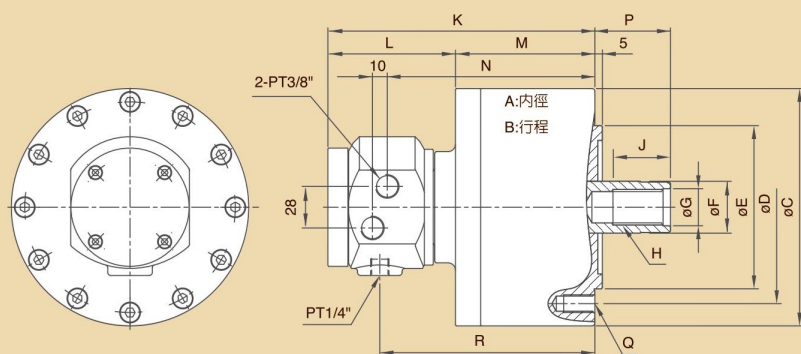

1. Super thin structure:

Super thin outer structure reduces the interference with machines and lowers the burden of machines.

2. Built-in Check Valve:

With built-in "check valve", work pieces can be effectively prevented from flying out during abrupt failure of pressure.

規格表 » Specifications

單位/UNIT:mm

型式/規格 MODEL /SPEC.	A	B	C	D	E (h7)	F	G (H8)	H	J	K	L
L1020R	105	20	135	100	80	30	21	M20x2.5P	35	172	86
L1225R	125	25	160	130	110	35	25	M24x3P	45	180	86
L1530R	150	30	190	130	110	45	31	M30x3.5P	45	189	84
L2035R	200	35	245	145	120	55	37	M36x4P	60	206.5	83

型式/規格 MODEL /SPEC.	M	N	P max.	P min.	Q	R	活塞行程 Piston Stroke (mm)	最高迴轉速 Max. Speed r.p.m. (min ⁻¹)	慣性矩I Moment of Inertia (kg·m ²)
L1020R	86	132	45	25	6-M10x1.5P	137	20	6000	0.013
L1225R	94	140	51	26	6-M12x1.75P	145	25	6000	0.023
L1530R	105	149	56	26	12-M12x1.75P	154	30	5500	0.048
L2035R	123.5	166.5	69	34	12-M16x2P	171.5	35	5500	0.098

型式/規格 MODEL /SPEC.	流量 Oil Leakage Rate (ℓ/min)	最高使用壓力 Max. Pressure kgf / cm ² (MPa)	活塞面積 Piston Area (cm ²)		最大推(拉)力 Max. Operating Force		淨重 Weight (kg)
			推力側 Push Side	拉力側 Pull Side	推力側 Push Side kgf (kN)	拉力側 Pull Side kgf (kN)	
L1020R	0.8	40 (3.9)	86	79	3100 (30.4)	2900 (28.4)	6.6
L1225R	0.8	40 (3.9)	122	113	4500 (44.1)	4100 (40.2)	8.8
L1530R	0.8	40 (3.9)	176	160	6300 (61.8)	6000 (58.8)	12.8
L2035R	0.8	40 (3.9)	314	290	11300 (110.8)	10400 (102.0)	22.5

★流量測試標準-壓力:30kgf/cm²(2.94MPa) 油溫:50°C ★Test standard of oil leakage: Pressure-30 kgf/cm²(2.94MPa), Oil temperature-50°C