

MR 3-JAW AIR CHUCKS

三爪氣壓夾頭

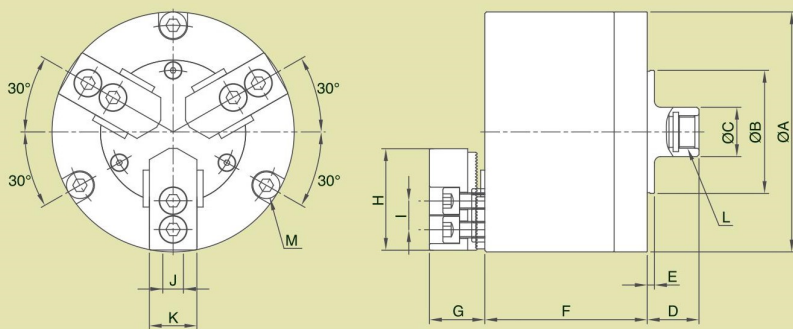

尺寸圖 » Dimensions



分度盤使用範例 » Operation Example for rotary table

CNC車床使用範例 » Operation Example for CNC Lathe

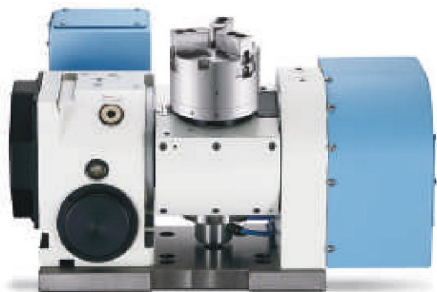

規格表 » Specifications

單位/UNIT:mm

型式/規格 MODEL / SPEC.	A	B	C	D	E	F	G	H	I	J	L	K	M
MR-04	117	60	24	25	3.5	84.5	26.7	49.5	14	10	5/8"-32UNF	23	3-M8x1.25P(PCDø104)
型式/規格 MODEL / SPEC.	活塞面積 Piston Area (cm ²)		柱塞行程 Plunger Stroke (mm)		爪行程直徑 Jaw Stroke (Diameter) mm		空壓夾持力 At Air Pressure 7 kgf/cm ² (0.7MPa) kgf		Gripping Force (kN)		最高迴轉速 Max. Speed r.p.m (min ⁻¹)	夾持範圍 Gripping Range	
MR-04	57		9		3.8		1100		(10.8)		3800	ø10~ø117	